

DataPort 25 Enhanced Carrier Install Guide

DataPort 25 USB & USB/FireWire-to-IDE Enhanced Carrier

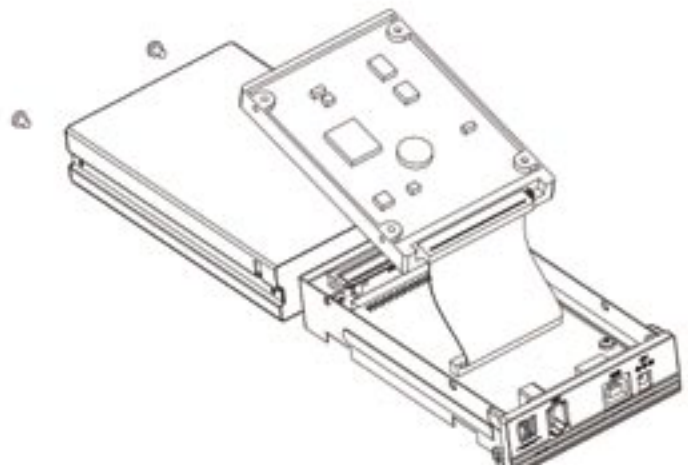
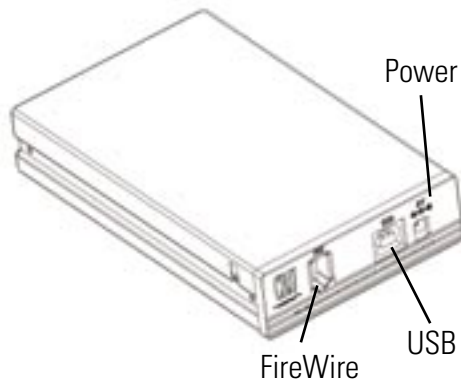

Installing a Hard Drive

The DataPort 25 Enhanced Carrier is designed to provide users the ultimate in data access flexibility. The DataPort 25 Enhanced Carrier is available in either USB (DataPort 25u) or USB and FireWire (DataPort 25c). The DataPort 25 Enhanced Carrier is intended to be used as a portable stand-alone external hard drive enclosure. It can also be inserted into the DataPort 25 frame where it operates at full IDE transfer rates (up to 133 mb/s). If your system provides standard USB or FireWire bus power the power supply is not required, freeing users from the tether of a power cord and providing access to your data anywhere.

Installing a hard drive in your DataPort 25 Enhanced Carrier

1. Remove the two screws from the back of the Enhanced Carrier. Slide the metal cover off.
2. Install the hard drive upside-down. First connect the power and data cables. Then use the provided screws to secure the hard drive with the bottom of the hard drive facing upwards.
3. Slide the cover back on to the carrier and secure it with the cover screws.

Frame Installation

Install the frame in an available 3.5" drive bay. Use the case manufacturer's rails if required. See CRU DataPort's website (www.CRU-DataPort.com) and the DataPort 25 Manual for more details.

Operation



Warning! Please do not touch the connector. Internal damage could result from electrostatic discharge.

When used with the DataPort 25 Frame, the lock functions as the power switch. The DataPort 25 Enhanced carrier operates as a standard IDE device.

When used as a stand alone USB or FireWire device follow the directions below to set up.

Setting up the drive for Windows ME/2000/XP or Mac OS.



Connect the DataPort 25 Enhanced Carrier to an available USB or FireWire port. No new drivers are required. The hard disk drive will be found and a window will pop up stating that new hardware has been detected. If the drive has previously been formatted, the drive will be accessible through My Computer on PCs or from the desktop on Macs.

For PCs:

- Right click on My Computer.
- Click on Manage.
- In the Storage sub-section, click on Disk Management to display a list of all the drives connected to your computer.
- If you have not used the drive before you will have to partition it. Left click on Action, select All Tasks and then left click on Create Partition.

REMEMBER, formatting will result in loss of all data on the hard drive.

- This will bring up the Create Partition Wizard screen. Follow the instructions and the drive will be ready to use.

For Macs:

If the drive is not formatted, you will be asked to initialize it. After initializing the drive, select the partition tab and select the desired partitions, then click ok. The new disks will be added to your desktop.

REMEMBER, formatting will result in loss of all data on the hard drive.

Removing the Hard Drive

For PCs:

- Quit all applications running on the external drive then right click the green arrow icon on the system tray.
- Select Remove/Eject.
- Highlight the USB Mass Storage Device in the dialog box then click Stop.
- Choose the external disk drive that you want to disconnect, then click Stop.
- Wait until the "You may safely remove this device" message appears.
- Unplug the cable from the computer.

WARNING: If your computer reports that the drive is busy, you must shut down your computer and then remove the drive. Failure to do so may result in data loss or corruption.

For Macs:

- When you disconnect the External drive from the Mac, close all windows and quit all applications that are running on the external drive.
- Drag the external drive icon into the Trash to dismount it from the desktop prior to unplugging the drive.

Product Warranty

CRU-DataPort (CRU) warrants the DataPort 25 Enhanced Carrier to be free of significant defects in material and workmanship for a period of one year from the original date of purchase. CRU's warranty is nontransferable and is limited to the original purchaser.

Limitation of Liability

The warranties set forth in this agreement replace all other warranties. CRU expressly disclaims all other warranties, including but not limited to, the implied warranties of merchantability and fitness for a particular purpose and noninfringement of third-party rights with respect to the documentation and hardware. No CRU dealer, agent or employee is authorized to make any modification, extension, or addition to this warranty. In no event will CRU or its suppliers be liable for any costs of procurement of substitute products or services, lost profits, loss of information or data, computer malfunction, or any other special, indirect, consequential, or incidental damages arising in any way out of the sale of, use of, or inability to use any CRU product or service, even if CRU has been advised of the possibility of such damages. In no case shall CRU's liability exceed the actual money paid for the products at issue. CRU reserves the right to make modifications and additions to this product without notice or taking on additional liability.

Register your product at www.CRU-DataPort.com and be automatically entered to win a free prize!

A5-025-0001 Rev. 1