

## Data Express DE100 SCSI Wide Install Guide

### Removable SCSI Wide Single-Ended Drive Enclosure

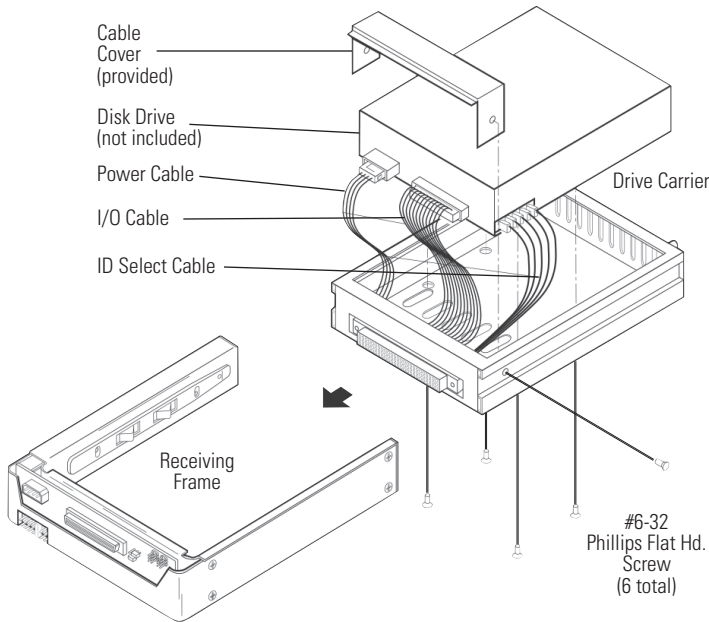

Figure 1: Drive Installation Assembly DE100 SCSI Wide 68-Pin

### Receiving Frame Motherboard

**ID Select Pins (J4):** Pins 1-14 are reserved. Pins 15-20 provide unit SCSI ID selection for the computer system or expansion chassis. For remote ID selection through an expansion chassis, the unit ID must be set to "0" or open (no jumpers installed) on these pins.

**Enable Termination Power to/from SCSI Bus (W1):** The rear panel contains the bus terminators (active) for 8-bit single-ended SCSI interface (jumper is factory-installed).

**Onboard (Receiving Frame) Termination (W2):** Position "A" is installed at the factory and will disable termination. Moving the jumper to position "B" will enable onboard termination.

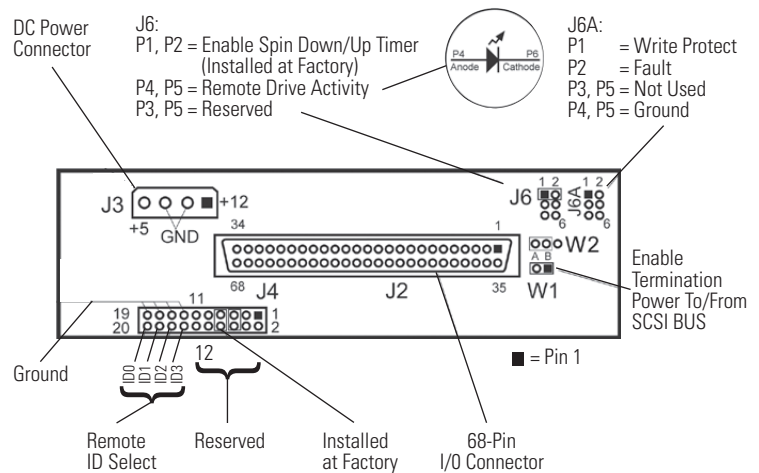

Figure 3: Receiving Frame Motherboard (rear view)

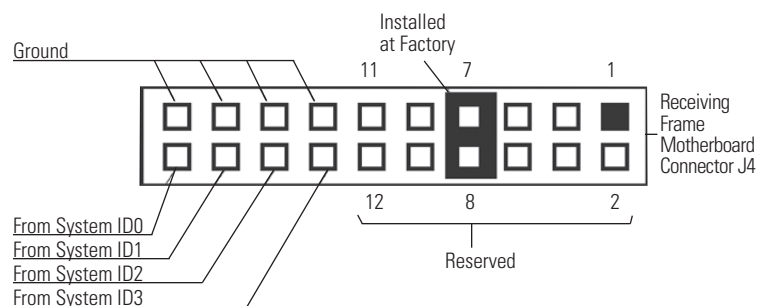

Figure 4: Receiving Frame Connector (J4) Pin Configuration

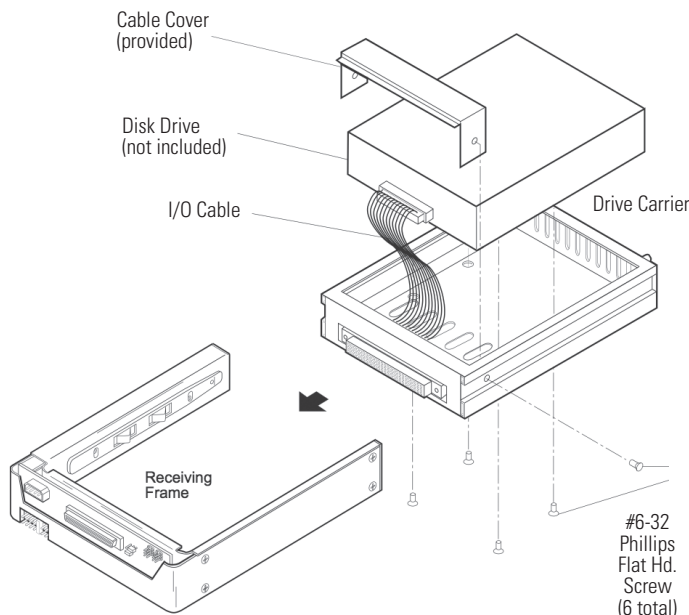

Figure 2: Drive Installation Assembly DE100 SCSI Wide SCA

## Typical 2MM Drive ID Pin Configuration

**NOTE:** Only applies to the DE100i-SW.

Figure below illustrates a typical SCSI ID select connection to a drive with 2mm ID select pins. The wires on the wire harness connect to the positive pin (or signal pins) on the disk drive. In some cases, the drive manufacturer will label the signal pins as Pin 1, 3, 5, 7, (instead of 0, 1, 2, 3 as shown in figure below). Also, in some cases, the even-numbered Pins 2, 4, 6 are used for Ground.

Attach the ID select cable to the drive using the 2mm connectors. Align the "ID0" pin with the black wire. Attach the 1.25mm connector on the other end of the ID select cable to the 1.25mm connector (J3B) provided on the signal distribution board, located inside the carrier. Refer to the manufacturer's documentation to disable termination on the drive.

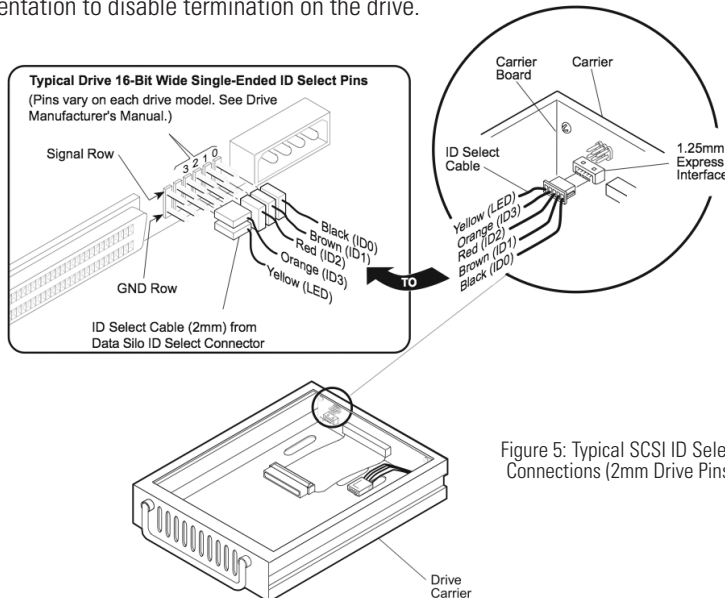

Figure 5: Typical SCSI ID Select Connections (2mm Drive Pins)

## Selecting the Unit ID Number

Use the alignment tool (provided) to select the ID number of the disk drive.

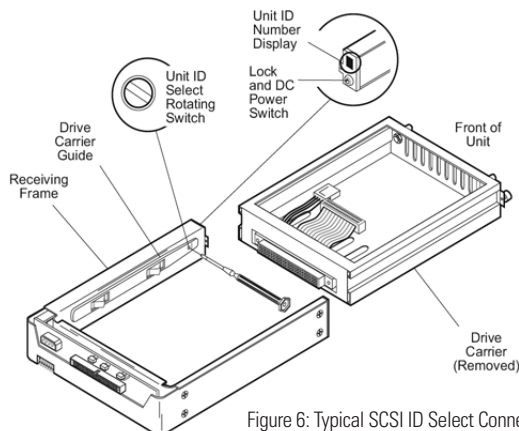

Figure 6: Typical SCSI ID Select Connections (2mm Drive Pins)

**NOTE:** The lock on the Data Express receiving frame functions as a lock and a DC power switch for the carrier unit. The lock **MUST** be engaged (turned counterclockwise) in order to supply power to the carrier and installed drive unit.

## Limited Product Warranty

CRU-DataPort (CRU) warrants the Data Express DE100 to be free of significant defects in material and workmanship for a period of five years from the original date of purchase. CRU's warranty is nontransferable and is limited to the original purchaser.

## Limitation of Liability

The warranties set forth in this agreement replace all other warranties. CRU expressly disclaims all other warranties, including but not limited to, the implied warranties of merchantability and fitness for a particular purpose and non-infringement of third-party rights with respect to the documentation and hardware. No CRU dealer, agent or employee is authorized to make any modification, extension, or addition to this warranty. In no event will CRU or its suppliers be liable for any costs of procurement of substitute products or services, lost profits, loss of information or data, computer malfunction, or any other special, indirect, consequential, or incidental damages arising in any way out of the sale of, use of, or inability to use any CRU product or service, even if CRU has been advised of the possibility of such damages. In no case shall CRU's liability exceed the actual money paid for the products at issue. CRU reserves the right to make modifications and additions to this product without notice or taking on additional liability.

## Certification

EMI Standard: FCC Part 15 Class B, CE  
EMC Standard: EN55022, EN55024

## FCC Certification

This device has been tested and found to comply with the limits for a Class B digital device, pursuant to Part 15 of the FCC rules. Operation is subject to the following two conditions:

1. This device may not cause harmful interference.
2. This device must accept any interference received; including interference that may cause undesired operation.

Register your product at [www.CRU-DataPort.com](http://www.CRU-DataPort.com)

A7-100-0007 Rev. 1