

DE110 USB 2.0-to-SATA/IDE Install Guide

Removable USB 2.0-to-SATA/IDE Drive Enclosure

Note: The SATA-to-USB 2.0 DE110 “universal” receiving frame (indicated by the BLUE LED) will accept both IDE (supports USB 1.1 and USB 2.0) and SATA (supports only USB 2.0) DE110 carriers.

For USB 2.0 operation, a USB 2.0 controller and USB cable (provided) are required.

Windows® 2000/XP/Vista all support USB 2.0.

For easy data backup and restoration, please refer to the Dantz® User’s Guide provided on the Dantz® Retrospect Backup software CD.

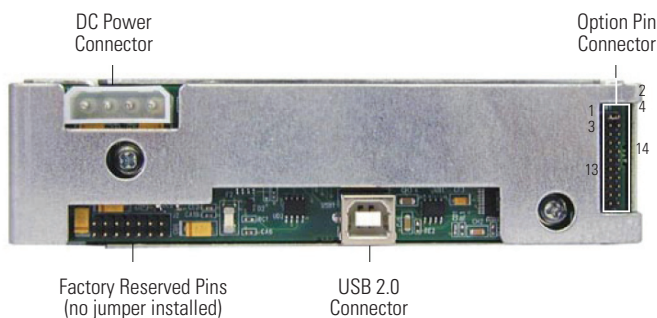

Figure 1: Receiving Frame Motherboard (rear view)

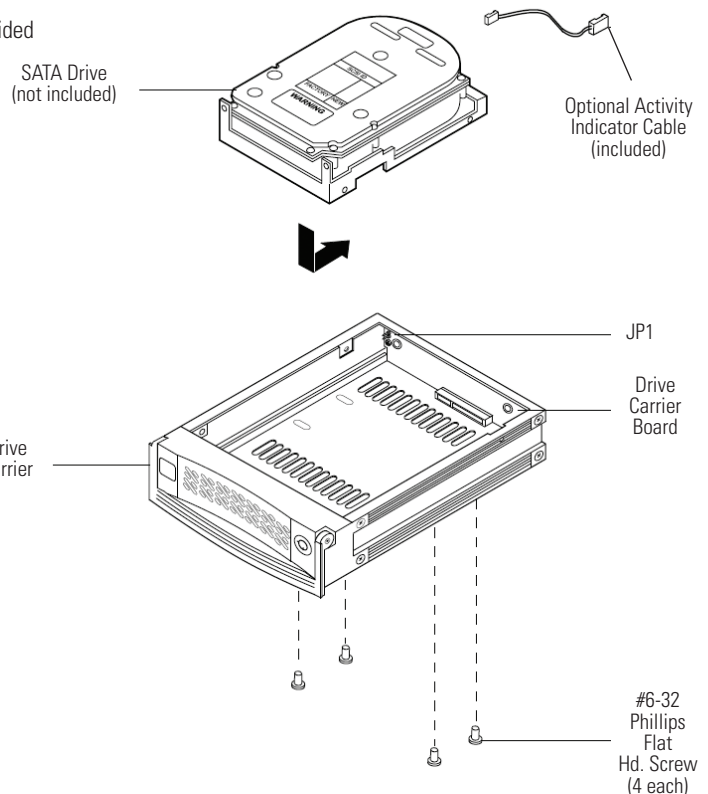

Figure 2: Drive Installation Assembly

IDO & ID1

Jumper is factory-installed on ID0. Change jumper position to Pins 3 & 4 for ID1 designation. ID0 & ID1 are for ID display purposes only. Refer to section “Unit ID Select Switch Settings” for further information.

Remote Activity LED (RLED)

For IDE drives pins 13 & 14 on the option pin connector provide power for a remote LED device activity indicator.

Drive Installation

Notes: A #2 Phillips screwdriver will be required during this procedure.

For Parallel ATA drives Master/Slave drive selection, drive can be configured as Cable Select (recommended) or as Master.

1. Carefully insert the drive into the carrier. Slide the drive towards the Drive Carrier Board, so that the I/O connector on the drive mates with the connector on the Drive Carrier Board (figure 2). Turn the drive/carrier assembly over.
2. Fasten the drive into place with four (4) #6-32 Phillips Flat Hd. Screws (figure 2). Some drives may require minor adjustments before securing into carrier with screws. If drive supports the Activity Indicator feature, connect one end of the Activity Indicator Cable (provided) to the drive and the other end to JP1 located on the Drive Carrier Board (figure 2).
3. Install the provided drive cover.

Installing the Receiving Frame

Notes: Use a #2 Phillips screwdriver for this procedure. Refer to your system motherboard manufacturer’s documentation for further information.

The drive should be installed into the carrier before installing the receiving frame into the mounting bay of a computer or expansion chassis.

1. Turn OFF power to the computer.
2. Open the computer system according to the manufacturer’s instructions. If necessary, temporarily remove any expansion boards that may make installation difficult.
3. Locate the USB connector(s) on the system motherboard. Depending on your system motherboard, it may have one or more 9-Pin USB connectors (with one typically connected to front USB ports on the PC), or it may have only a 4-Pin USB connector.

If your system motherboard has several 9-Pin USB connectors, proceed to Step 4.

If your system motherboard has only one 9-Pin USB connector, proceed to Step 5.

If your system motherboard has only a spare 4-Pin USB connector (instead of 9-Pin), proceed to Step 6.

4. Locate a spare 9-Pin USB connector on the system motherboard and connect the female connector on the split USB cable (provided) to it (figure 3).

Typical System Motherboard (your system may vary)

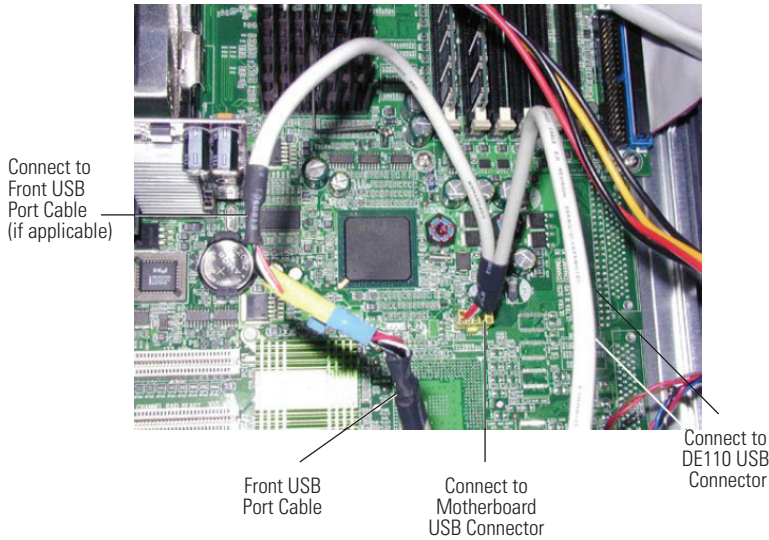

Figure 3: Connecting the Split USB Cable to the System

5. If your system motherboard has only one 9-Pin USB connector and it is connected to the front USB ports, disconnect the front USB port cable from the system motherboard USB connector. Connect the female connector on the split USB cable (provided) to the newly vacated USB connector located on the system motherboard (figure 3). If applicable, connect the male connector on the split USB cable to the front USB port cable (figure 3). Make sure the red wires on both cable are correctly aligned.

Note: Connecting the DE110 to the system motherboard's only USB connector will disable one of the front USB ports (if applicable). Only the lower (or second) USB port will still function while the DE110 is installed.

6. If your system motherboard has only a spare 4-Pin USB connector, connect the female connector on the split USB cable (provided) to it. The female connector on the split USB cable has two rows of wires, a 5-wire row and a 4-wire row. Make sure to connect the 5-wire row to the system motherboard's 4-Pin USB connector (refer to your system motherboard manufacturer's documentation for information on the pin assignments.)

Note: When connecting the 5-wire row to the 4-pin USB connector, make sure that the wires on the cable correspond to the appropriate pins (refer to your system motherboard manufacturer's documentation for information on pin assignments).

7. Install the DE110 receiving frame into the computer.
8. Connect the remaining end of the split USB cable to the DE110 USB connector located on the receiving frame motherboard (figure 1).
9. Connect the power cable from the DC power supply in the computer or expansion chassis to the power connector on the DE110 receiving frame. Refer to figure 1 for the DE110 receiving frame power connector location.

Unit ID Select Switch Settings

Note: The unit ID number display is for ID display purposes only.

The following table lists the unit ID select switch settings.

Unit ID Select Position	0	1	2	3	4	5	6	7	8	9
Unit ID Number Display	Blank	0	1	Blank	Blank	2	3	Blank	Blank	Blank

Selecting the Unit ID Number: Use the alignment tool (provided) to select the ID number of the disk drive.

Note: The lock on the Data Express receiving frame functions as a lock and a DC power switch for the carrier unit. The lock **MUST** be engaged (turned counter-clockwise) in order to supply power to the carrier and installed drive unit.

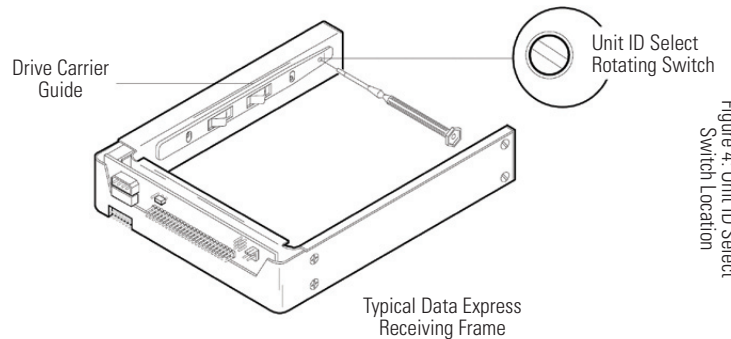

Figure 4: Unit ID Select Switch Location

Limited Product Warranty

CRU-DataPort (CRU) warrants the Data Express DE110 to be free of significant defects in material and workmanship for a period of one year from the original date of purchase. CRU's warranty is nontransferable and is limited to the original purchaser.

Limitation of Liability

The warranties set forth in this agreement replace all other warranties. CRU expressly disclaims all other warranties, including but not limited to, the implied warranties of merchantability and fitness for a particular purpose and non-infringement of third-party rights with respect to the documentation and hardware. No CRU dealer, agent or employee is authorized to make any modification, extension, or addition to this warranty. In no event will CRU or its suppliers be liable for any costs of procurement of substitute products or services, lost profits, loss of information or data, computer malfunction, or any other special, indirect, consequential, or incidental damages arising in any way out of the sale of, use of, or inability to use any CRU product or service, even if CRU has been advised of the possibility of such damages. In no case shall CRU's liability exceed the actual money paid for the products at issue. CRU reserves the right to make modifications and additions to this product without notice or taking on additional liability.

Certification

EMI Standard: FCC Part 15 Class B, CE
EMC Standard: EN55022, EN55024

FCC Certification

This device has been tested and found to comply with the limits for a Class B digital device, pursuant to Part 15 of the FCC rules. Operation is subject to the following two conditions:

1. This device may not cause harmful interference.
2. This device must accept any interference received; including interference that may cause undesired operation.

Register your product at www.CRU-DataPort.com