

Data Express DE75 ATA 133 Install Guide

Removable Ultra ATA133 Drive Enclosure

Drive Installation Overview

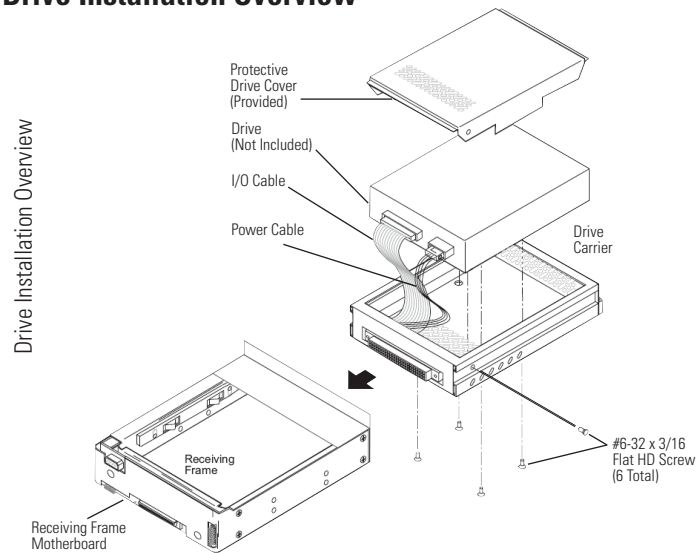

JP6 Header:

Master/Slave Setting (JP6 ID0 & ID1):

ID0: Jumper installed on Pins 1 & 2 (Factory Default) for Master configuration.

ID1: Jumper installed on Pins 3 & 4 for Slave configuration.

Remote Drive Activity (JP6 RLED): Pins 17 & 18 are used for remote drive activity.

Jumper (JP6 DDA): Factory-installed on Pins 15 & 16 - Do not remove!

JP4 Option: Refer to the full version of the DE75i-A100 Manual for further information.

Master/Slave Drive Selection

There are two (2) ways to set the Master/Slave drive designation for the DE75i-A100 unit.

Method 1 (Recommended)

Using the factory-installed jumper on your IDE drive

In most cases, the drive will be factory-configured as a Master Ultra ATA133 drive using a jumper plug on the drive itself. No configuration changes are required. For multiple drive configurations, it is necessary to set the first IDE drive as Master and the second IDE drive to Slave. This can be done by changing the jumper on the Ultra ATA133 drive itself (refer to your drive manufacturer documentation).

This method requires no additional configuration of the drive carrier circuit board.

Receiving Frame Motherboard

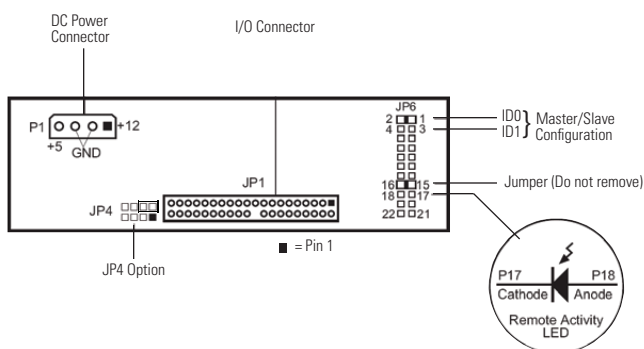

Receiving Frame Motherboard (Rear View)

Receiving Frame Motherboard

DC Power Connector (P1): The Data Express uses a standard 4-pin DC Power Connector to accept DC power.

I/O Connector (JP1): The input/output connector provides a standard interface for all IDE signals.

However, the appropriate jumper setting must still be configured on JP6 (ID0 & ID1) located on the receiving frame motherboard (Figure 2). For Master setting, install jumper on ID0 (Pins 1 & 2). For slave setting, install jumper on ID1 (Pins 3 & 4).

Skip the Method 2 section and continue with installation.

Method 2

Using the hard-wire connector JP3 on the drive carrier circuit board to allow drive carrier interchangeability between Master/Slave configured receiving frames

To allow this interchangeability it is necessary to set the Master/Slave drive selection by a hard-wire connection between the drive and the drive carrier circuit board.

This method requires the fabrication of a cable wire (not provided). Refer to the DE75i-A100 Manual for further information regarding Method 2.

Unit ID Select Switch Settings

The following table lists the unit ID select switch settings and the valid AT/IDE unit numbers. Invalid switch settings are indicated by an "X" and will result in a blank display in the receiving frame window.

Unit ID Select Position	0	1	2	3	4	5	6	7	8	9
Drive Selection	X	Master	Slave	X	X	Master	Slave	X	X	X
Unit ID Number Display	Blank	0	1	Blank	Blank	2	3	Blank	Blank	Blank

Unit ID Select Switch Settings

Note: The unit ID number display is for ID display purposes only. The master/slave setting must still be set on the drive itself (refer to the drive manufacturer's documentation for further information).

Selecting the Unit ID Number: Use the alignment tool (provided) to select the ID number of the disk drive.

Unit ID Select Switch Location

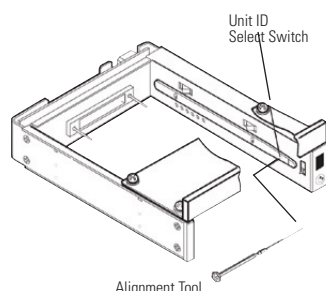

Note: The lock on the Data Express serves as a power switch. It must be engaged (turned counterclockwise) for the Data Express to power up and function properly.

Limited Product Warranty

CRU-DataPort (CRU) warrants the Data Express DE75 to be free of significant defects in material and workmanship for a period of five years from the original date of purchase. CRU's warranty is nontransferable and is limited to the original purchaser.

Limitation of Liability

The warranties set forth in this agreement replace all other warranties. CRU expressly disclaims all other warranties, including but not limited to, the implied warranties of merchantability and fitness for a particular purpose and non-infringement of third-party rights with respect to the documentation and hardware. No CRU dealer, agent or employee is authorized to make any modification, extension, or addition to this warranty. In no event will CRU or its suppliers be liable for any costs of procurement of substitute products or services, lost profits, loss of information or data, computer malfunction, or any other special, indirect, consequential, or incidental damages arising in any way out of the sale of, use of, or inability to use any CRU product or service, even if CRU has been advised of the possibility of such damages. In no case shall CRU's liability exceed the actual money paid for the products at issue. CRU reserves the right to make modifications and additions to this product without notice or taking on additional liability.

Certification

EMI Standard: FCC Part 15 Class B, CE
EMC Standard: EN55022, EN55024

FCC Certification

This device has been tested and found to comply with the limits for a Class B digital device, pursuant to Part 15 of the FCC rules. Operation is subject to the following two conditions:

1. This device may not cause harmful interference.
2. This device must accept any interference received; including interference that may cause undesired operation.

Register your product at www.CRU-DataPort.com

A7-075-0004 Rev. 2.1