

# DataPortable 250 Installation Guide

## Hard Drive Installation

- Step 1. Remove the front and side screws.
- Step 2. Remove the top and bottom covers.
- Step 3. Connect the hard drive to the data connector and secure the hard drive with the bottom mount screws provided.
- Step 4. Replace the top and bottom covers.
- Step 5. Connect the primary USB cable (see Figure 2) to an available USB port on the host computer. The DataPortable 250 is powered through the USB cable. If enough power is not provided through the primary USB cable, connect the secondary cable to the host computer.

**Note:** The LED on the back of the DataPortable 250 enclosure will glow blue when it is powered on and will flicker during drive activity.

**Note:** The OTB "One Touch Backup" button will not function without software. This feature is not supported at the present time.

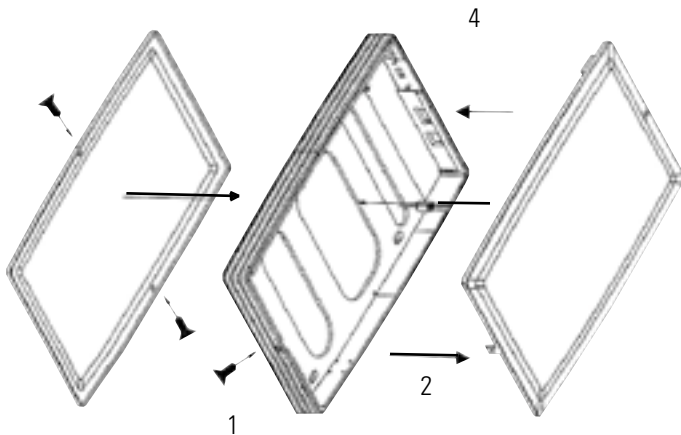

Figure 1: Hard Drive Installation



Figure 2: Dual Connector USB Cable

## Setting up the drive for Windows 2000/XP or Mac OS 9.x/X

Connect the DataPortable 250 to any available USB port. No new drivers are required. The hard disk drive will be found and a window will pop-up stating that new hardware has been detected. If the drive is formatted it will be accessible through My Computer on PCs or from the desktop on Macs. For best performance, connect via USB 2.0.

### For PCs:

- Right click on My Computer.
- Click on Manage.
- In the Storage sub-section, click on Disk Management to display a list of all the drives connected to your computer.
- If you have not used the drive before you will have to partition it. Left click on Action, select All Tasks and then left click on Create Partition.



**REMEMBER, partitioning the drive will require the drive to be formatted; formatting will result in loss of all data on the hard drive.**

- This will bring up the Create Partition Wizard screen.
- Follow the instructions and the drive will be ready for use.

#### **For Macs:**

If the drive is not formatted, you will be asked to initialize it. After initializing the drive, select the partition tab and select the desired partitions, then click ok. The new disk will be added to your desktop.

**REMEMBER, formatting will result in loss of all data on the hard drive.**

#### **Removing the Hard Drive**

##### **For PCs:**

- Quit all applications running on the external drive then right click the green arrow icon in the system tray.
- Select Remove/Eject.
- Highlight the USB Mass Storage Device in the dialog box then click Stop.
- Choose the external disk drive that you want to disconnect, then click Stop.
- Wait until the "You may safely remove this device" message appears.
- Unplug the data cable from the computer.

**WARNING:** If your computer reports that the drive is busy, you must shut down your computer and then remove the drive. Failure to do so may result in data loss or corruption.

#### **For Macs:**

- To disconnect the External drive from the Mac, close all windows and quit all applications that are running on the DataPortable 250.
- Drag the external drive icon into the Trash to dismount it from the desktop.
- Unplug the data cable from the computer.

#### **Product Warranty**

CRU-DataPort (CRU) warrants the DataPortable 250 to be free of significant defects in material and workmanship for a period of one year from the original date of purchase. CRU's warranty is nontransferable and is limited to the original purchaser.

#### **Limitation of Liability**

The warranties set forth in this agreement replace all other warranties. CRU expressly disclaims all other warranties, including but not limited to, the implied warranties of merchantability and fitness for a particular purpose and non-infringement of third-party rights with respect to the documentation and hardware. No CRU dealer, agent or employee is authorized to make any modification, extension, or addition to this warranty. In no event will CRU or its suppliers be liable for any costs of procurement of substitute products or services, lost profits, loss of information or data, computer malfunction, or any other special, indirect, consequential, or incidental damages arising in any way out of the sale of, use of, or inability to use any CRU product or service, even if CRU has been advised of the possibility of such damages. In no case shall CRU's liability exceed the actual money paid for the products at issue. CRU reserves the right to make modifications and additions to this product without notice or taking on additional liability.

**Register your product at [www.CRU-DataPort.com](http://www.CRU-DataPort.com) and be automatically entered to win a free prize!**

A5-250-0001 Rev. 1.1